

## INSTRUCTIONS

# Series 1201 & 1202

## DIFFERENTIAL PRESSURE INSTRUMENTS



**Orange Research Inc.**

140 Cascade Boulevard, Milford, Connecticut 06460  
203 877-5657 800 989-5657 Fax: 203 783-9546  
www.orangeresearch.com

Your new Orange Research Differential Pressure Instrument is a rugged instrument featuring simplicity of design to provide dependable and efficient service. Because it is an instrument it should be handled with care. Read all instructions carefully before attempting to install the instrument.

**CAUTION:** Do not exceed nameplate maximum operating pressure. Use only fluids compatible with wetted parts.

## HOW IT WORKS

The instrument operates on the difference between two pressures (delta-P). The sensing element is a spring biased piston which moves linearly in proportion to the difference between two basic pressures. A magnet on the **HI** pressure side of the piston assembly moves with the piston and rotates a follower magnet located adjacent to the pressure cavity. The gauge pointer is located at the end of the rotary magnet shaft and rotates with the magnet to provide gauge readings proportional to differential pressure variations. There are no mechanical seals between the pressure side of the instrument and the gauge mechanism side. This is accomplished by coupling the forces between two adjacent magnets through a solid wall.

**SWITCH UNITS:** On switch and indicating switch models, reed switches are located adjacent to the pressure chamber and are actuated when the piston magnet field interacts at a preset point with the reed switch armature. Reed switch set points are adjustable.

## INSTALLATION

Check instrument and identify the **HI** and **LO** markings. **HI** identifies the high pressure port; **LO** the low pressure port. If instrument is installed backwards, it will neither operate nor be damaged. Reverse connections if installed backwards. The instrument can be line mounted, bracket mounted or panel mounted depending upon the model purchased.

Under normal conditions Series 1201 Instruments are designed for line pressure to 3000 psig and can sustain a continuous 3000 psig forward or reverse overpressure. Series 1202 Instruments are designed for line pressures to 5000 psig and can sustain a continuous 5000 psig forward or reverse overpressure.

It is recommended that the instrument be located above the pressure source to allow drainage of the unit.

**IMPORTANT:** Because of the magnetic movement, this instrument should never be mounted in direct contact with a steel surface. Otherwise a calibration shift will occur. Mount the instrument so that the pressure body is at least 1" away from metal surfaces with non-magnetic spacers or an aluminum-mounting bracket. Flush panel mounted instruments will not be affected by contact with aluminum panels. However, 2" and 2½" gauges flush mounted in a steel panel may require resetting of the pointer at zero. (this should be done at time of manufacture but can be reset in the field with a small loss of accuracy.)

## MAINTENANCE

Other than replacing broken lens there is only one area where this instrument may need attention. Erratic pointer or switch action may indicate that cleaning is required. For cleaning:

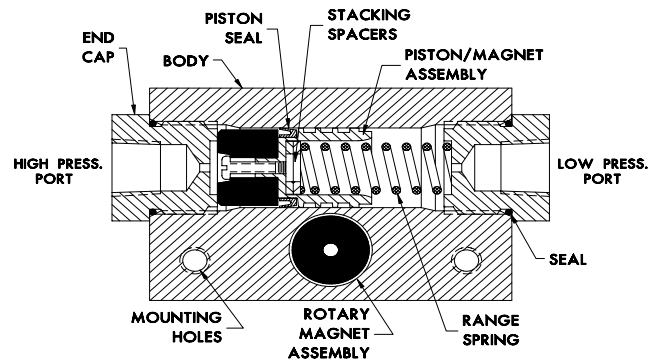

1. Remove the unit from service.
2. Remove both end caps with a 1" spanner wrench.
3. Remove the range spring and the piston/magnet assembly. **BE CAREFUL NOT TO LOSE STACKING SPACERS.**
4. Clean parts in a solvent solution after removing O-Ring seals from the end caps since some solvents will attack the seal material.
5. It is good to practice to replace the O-Ring seals while the instrument is dismantled. **DO NOT ATTEMPT TO MOVE THE TEFLON PISTON SEAL FROM THE PISTON.** If piston seal is damaged order a new piston/magnet assembly.

### To reassemble:

1. Lubricate the piston bore lightly with petroleum jelly, light oil or silicone grease.
2. Install the **HI** end cap first and tighten.
3. Install the piston/magnet assembly (magnet facing **HI** pressure port).
4. Insert stacking spacers in bottom of piston spring pocket and insert range spring.
5. Reassemble **LO** end cap making certain that spring is seated in the end cap spring pocket.
6. Tighten **LO** end cap and the instrument is now ready for service.

**IMPORTANT:** Magnet end of piston/magnet assembly **MUST** be facing the **HI** pressure port of the instrument, otherwise, the instrument will not operate.

**LENS REPLACEMENT:** To replace a broken lens, check to see if the lens is held on by a bezel or a snap-ring. To remove a bezel, which is a pressed on cover, either twist off by hand (watch out for the broken glass) or pry off with a screwdriver. To remove a snap-ring, pry out the ring with a small screwdriver. Remove all glass chips, insert new lens and re-insert the bezel or snap. With snap-rings, locate the ring joint at the bottom of the gauge.

**POINTER REPLACEMENT:** (Probably damaged when lens was broken). Remove bezel or snap-ring as previously described and clean out glass chips. Remove old pointer with pointer puller or two small screwdrivers opposite each other under pointer hub. Pry off evenly being careful not to bend the pointer shaft. Install new pointer dead on zero. Re-install lens, as described under lens replacement.

## SWITCH ADJUSTMENT

Reed switch set points are field adjustable. On Indicating Switches, the reed switches can be adjusted over the top 80% of the gauge range. On Switch models the reed switches can be adjusted over the range shown on the nameplates.

To change the reed switch setting, a source of pressure will be needed with the instrument. Loosen the screw holding the reed switch. To increase the set point, slide the switch tube toward the **LO** port. To decrease the set point, slide the switch tube toward the **HI** port. Repeat as required until new setting is reached. Tighten the screw holding the switch tube in place and recheck the new actuation point. **CAUTION:** Do not over tighten the switch holding screw- this is a cone point set screw and digs into the tube with light pressure. (in some cases, it might be necessary to reverse the switch tube end for end to locate the new actuation point- this is normal procedure.

### SWITCH WIRE COLOR

- A SPST white and white
- B SPST green(N/C); blue(common)
- C SPDT green(N/C); red(N/O); blue(common)

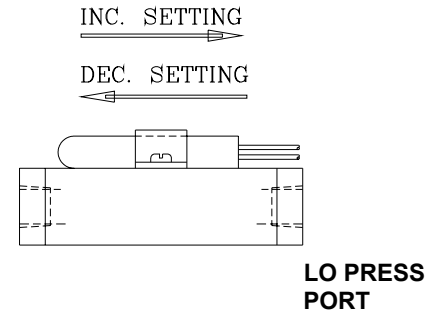

## REPLACEMENT PARTS

GAUGE DIA.	GLASS LENS	PLASTIC LENS	POINTER	SST BEZEL (press-fit)
2"	GG1-1	GG2-1	AF15-1	M1-5
2 1/2"	GG1-2	GG2-2	AF15-2	M2-5
3 1/2"	GG1-3	GG2-3	AF15-3	M4-5
4 1/2"	GG1-4	GG2-4	AF15-4	M5-5
6"	GG1-5	GG2-5	AF15-5	---

### END CAP "O"-RING

Buna N	BB1-1A
Viton	BB1-1B
Fluorosilicone	BB1-1C
Teflon	BB1-1F
EPDM	BB1-1E

### PISTON/MAGNET ASSEMBLY

Aluminum	SD12-1
316 SST	SD12-3
PVC	SD12-4
Naval Brass	SD12-5

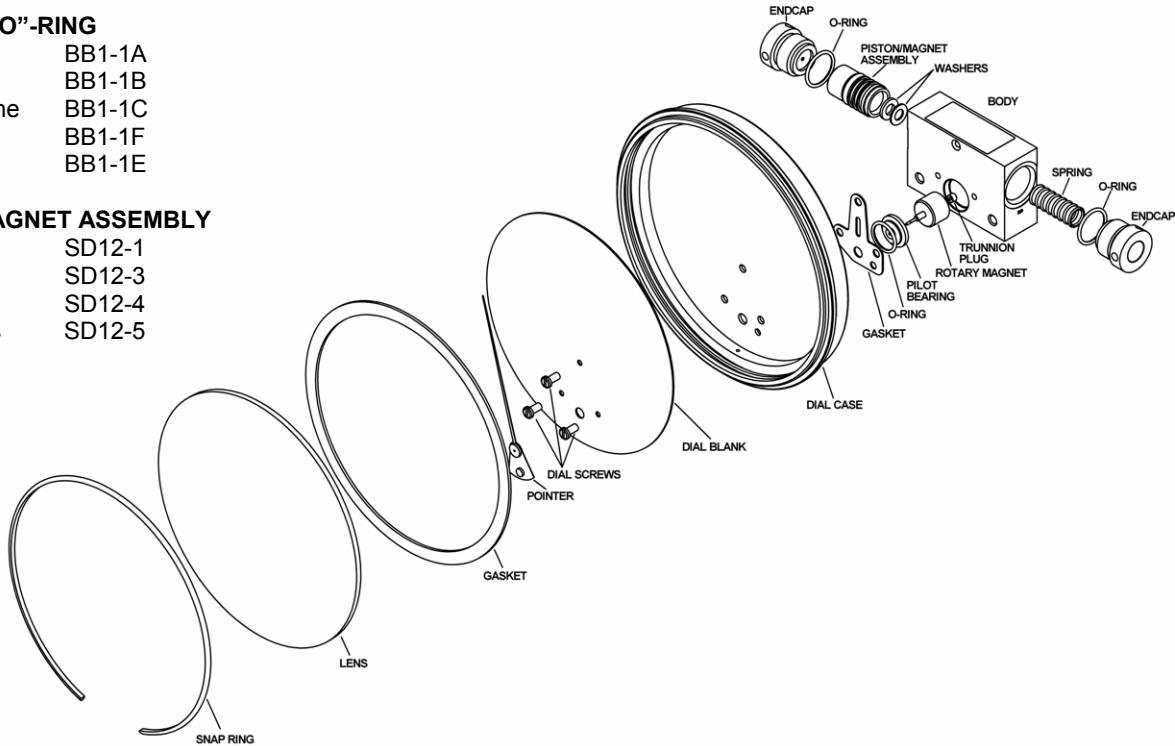

### RECALIBRATION

Recalibration of this instrument is not required. However, if the range spring is damaged or a new dial is required, the instrument must be returned to the factory for the parts and recalibration.

**NOTE:** When ordering replacement parts, identify instrument SO# or WO# from the nameplate. Identify parts required and quantity.