

INSTRUCTIONS

Series 2220, 2320, 2420

IN-LINE FLOW INSTRUMENTS

Variable-Orifice

Orange Research Inc.

140 Cascade Boulevard, Milford, Connecticut 06460
203 877-5657 800 989-5657 Fax: 203 783-9546
www.orangeresearch.com

Your new Orange Research in-line flow meter is a rugged instrument featuring a simple and reliable design. Read all instructions carefully before attempting to install the instrument.

Caution: Do not exceed maximum operating pressure listed on instrument label. Use only with fluids compatible with wetted parts.

HOW IT WORKS

The instrument operates on the difference between two pressures (delta-P). This delta-P develops as flow is established through a variable orifice which is formed between the spring-biased metering cone and the end cap in which the cone rests (see Fig. A). The variable orifice allows the cone to move linearly in proportion to the delta-P. A magnet located on the metering cone moves with the cone and rotates a follower magnet located in a chamber adjacent to the fluid cavity. The gauge pointer is located at the end of the rotary magnet shaft and rotates with the magnet to provide gauge readings proportional to flow. There are no mechanical seals between the flow chamber and the rotary chamber. This is accomplished by coupling forces between two adjacent magnets through a solid wall.

SWITCH UNITS



Reed switches are located adjacent to the flow chamber and are actuated when the cone magnet field interacts at a preset point with the reed switch armature. Switch set points are adjustable.

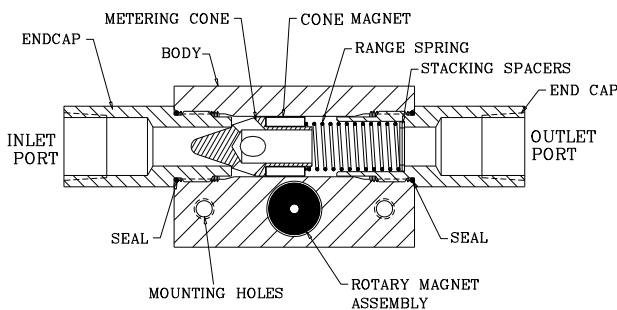

Fig. A

2220 Series shown- images vary by model

INSTALLATION

Check the instrument and identify the inlet and outlet markings. "In" identifies the flow inlet port; "Out" the flow outlet port. Install units in your piping system using standard pipe fitting procedures. Thread sealing compound should be kept out of the unit. The instrument can be line mounted, bracket mounted, or panel mounted depending upon the model purchased.

It is recommended that a 50 μ filter be installed upstream of the flow instrument to assure a clean fluid medium through the

instrument. Also, good flow measurement practices recommend straight runs of pipe equal to at least 10 pipe diameters upstream and 5 pipe diameters downstream of the gauge to reduce flow turbulence.

Important: Because of the magnetic nature of this instrument, it should never be mounted in direct contact with a steel surface, otherwise a calibration shift may occur. Mount the instrument so that the body is at least 1" away from steel surfaces using non-magnetic spacers or an aluminum mounting bracket.

Unless otherwise specified at the time of order, instruments are calibrated in the horizontal position. Instruments should always be mounted in the same position as they were calibrated to eliminate positional errors.

MAINTENANCE

Your Orange Research instrument will provide years of maintenance-free operation. Other than replacing a broken lens there is only one area where the instrument may need attention. Erratic pointer or switch action may indicate that cleaning is required. Please consult the factory for guidance on how to properly clean your instrument.

SWITCH ADJUSTMENT

The reed switch set points can be adjusted over the top 80% of the gauge range.

To change the reed switch setting, set the flow rate to the desired switch set point. Loosen the set screw holding the switch in place. To increase or decrease the set point for all units, slide the switch tube until the switch actuates. If applicable, tighten the set screw to hold the switch in place and recheck the new actuation point.

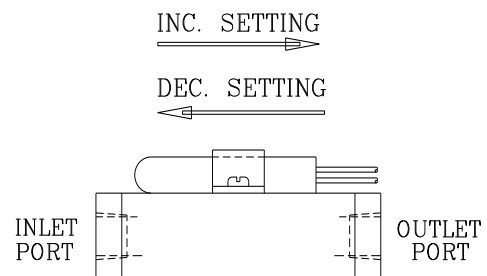

Caution: Do not overtighten the switch holding set screw. (In some cases, it might be necessary to reverse the switch tube end-for-end to locate the new actuation point. This is a normal procedure.)

Switch Wire Color Code

- A SPST white and white
- C SPDT green (N.C.), red (N.O.), and blue (common)
- B SPST (N.C.) green and blue

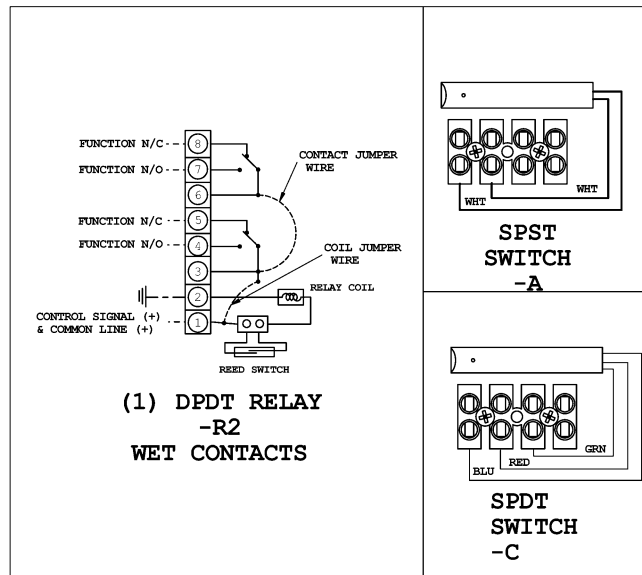

 **WARNING:** This product contains Nickel, a chemical known to the State of California to cause cancer. For more information go to: www.p65warnings.ca.gov