

INSTRUCTIONS

Series 1504, 1514, 1804

DIFFERENTIAL PRESSURE INSTRUMENTS

Diaphragm Sensor – Explosion-Proof

Your new Orange Research Differential Pressure Instrument is a rugged instrument featuring simplicity of design to provide dependable and efficient service. Because it is an instrument it should be handled with care. Read all instructions carefully before attempting to install the instrument.

CAUTION: Do not exceed maximum operating pressure listed on instrument label. Use only fluids compatible with wetted parts.

HOW IT WORKS

The instrument operates on the difference between two pressures (delta-P). The sensing element is a spring biased diaphragm which moves linearly in proportion to the difference between two basic pressures. A magnet on the **HI** pressure side of the diaphragm assembly moves with the diaphragm and rotates a follower magnet located adjacent to the pressure cavity. The gauge pointer is located at the end of the rotary magnet shaft and rotates with the magnet to provide gauge readings proportional to differential pressure variations. There are no mechanical seals between the pressure side of the instrument and the gauge mechanism side. This is accomplished by coupling the forces between two adjacent magnets through a solid wall.

SWITCHES: A secondary magnet, located in the extension tube also moves with the pressure sensor. Reed switches, mounted externally on the pressure extension tube are actuated when the field of the secondary magnet interacts at a preset point with the reed switch armatures.

NOTE: This instrument will provide $\pm 2\%$ accuracy full scale.

INSTALLATION

Check instrument and identify the **HI** and **LO** markings. **HI** identifies the high-pressure port; **LO** the low-pressure port. If the instrument is installed backwards, it will neither operate nor be damaged. The instrument can be line mounted, pipe mounted or panel mounted.

Installation Notes:

- Do not mount directly to steel surfaces...this could affect the magnetic sensors...mounting 1 inch from ferrous metals is recommended
- If there is particulate in the line, insert a screen (approx. 100 micron) to block the particulate from becoming lodged in the instrument
- Do not install on systems for highly viscous fluids or where fluid may become hardened over time
- Do not install on system with iron in the fluid...the iron can become attached to the magnetic sensors
- Install the unit above the process line to prevent particulate settling in the instrument
- We recommend isolating the instrument from the system pressure using valves...3 or 5 way manifold valves are common

Orange Research

140 Cascade Boulevard, Milford, Connecticut 06460
203 877-5657 800 989-5657 Fax: 203 783-9546
www.orangeresearch.com

- Open valves connected to our instrument slowly, to protect the diaphragm sensor from damage
- Before installation, refer to our Specification Sheets (on our website) to identify instrument component materials & double check for chemical compatibility

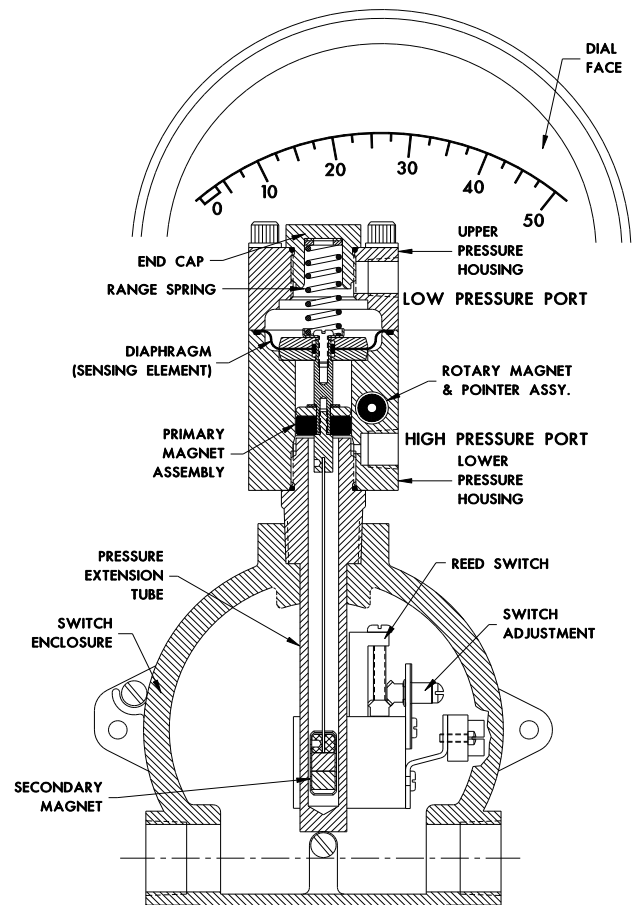

1514 Series shown – images vary by model

SWITCH ADJUSTMENT

Reed switch set points are field adjustable. On Indicating Switches, the reed switches can be adjusted over the top 80% of the gauge range. On Switch models the reed switches can be adjusted over the range shown on the nameplate.

Minor Switch Adjustments*

To change the switch adjustment:

1. Unscrew the cover on the electrical enclosure. This cover will be facing the front of the instrument on the lower section of the assembly.
NOTE: Panel mounting reversed.
2. Switches can now be adjusted by turning the adjustment screws located above the terminal strips on the switch saddle assembly.
 - A. Clockwise rotation will increase the switch set point.
 - B. Counter-clockwise rotation will decrease the switch set point.
3. Replace the cover.

* For major switch adjustments, contact Orange Research.

SWITCH REPLACEMENT:

1. Unscrew the cover of the electrical enclosure, remove the cover.
2. Disconnect the switch wires from the terminal block. Note the locations of the wires.
3. Remove (2) screws that fasten the terminal block bracket. Remove the bracket (Relay models do not have this bracket).
4. Loosen, BUT DO NOT REMOVE, the (2) switch adjustment plate retaining screws (Relay models will have 3 or 4 retaining screws). Turn screws 3 revolutions counterclockwise. Removal of retaining screws will make re-assembly more difficult.
5. Pull up on the switch adjustment plate and remove the switch & gear assembly (it may be necessary to loosen the saddleblock lock screw and slide the entire saddleblock assembly down towards the conduit connections).
6. Insert the new switch & gear assembly into the saddle block.
7. Tighten the saddleblock lock screw, if necessary.
8. Tighten the (2) screws on the switch adjustment retaining plate (Relay models will have 3 or 4 retaining screws).
9. Re-assemble the (2) screws that hold down the terminal block bracket.
10. Connect the switch wires to the terminal block.
11. Adjust switch as necessary following the SWITCH ADJUSTMENT procedure.

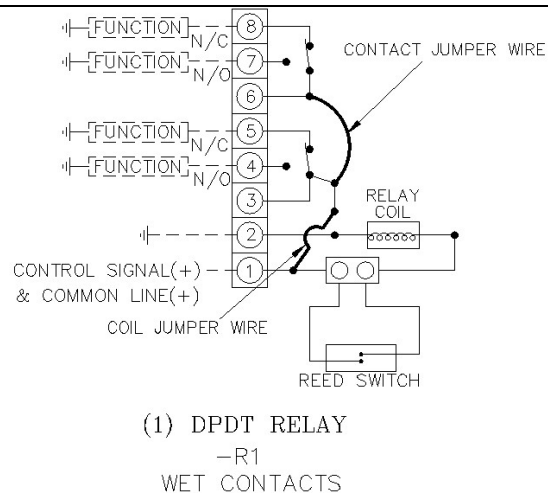
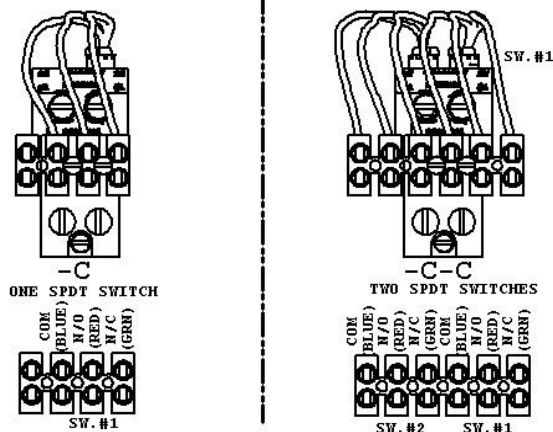
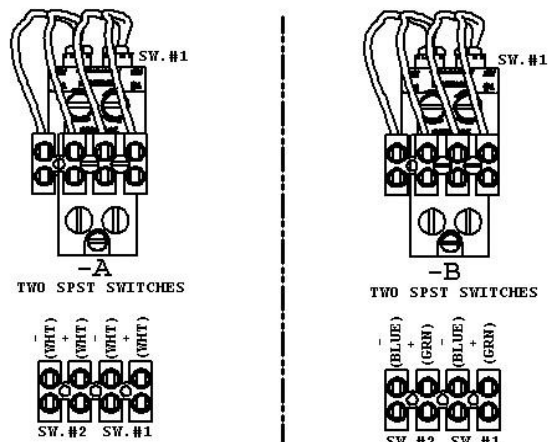

WARNING: This product contains Nickel, a chemical known to the State of California to cause cancer. For more information go to: www.p65warnings.ca.gov