

INSTRUCTIONS

Series 1204

DIFFERENTIAL PRESSURE INSTRUMENTS

Piston Sensor – Explosion Proof

Your new Orange Research Differential Pressure Instrument is a rugged instrument featuring simplicity of design to provide dependable and efficient service. Because it is an instrument it should be handled with care. Read all instructions carefully before attempting to install the instrument.

CAUTION: Do not exceed maximum operating pressure listed on instrument label. Use only fluids compatible with wetted parts, including seals.

HOW IT WORKS

The instrument operates on the difference between two pressures (delta-P). The sensing element is a spring biased piston which moves linearly in proportion to the difference between two basic pressures. A magnet on the **HI** pressure side of the piston assembly moves with the piston and rotates a follower magnet located adjacent to the pressure cavity. The gauge pointer is located at the end of the rotary magnet shaft and rotates with the magnet to provide gauge readings proportional to differential pressure variations. This is accomplished by the coupling forces between two adjacent magnets through a solid wall.

SWITCHES: A secondary magnet, located in the extension tube also moves with the pressure sensor. Reed switches, mounted externally on the pressure extension tube are actuated when the field of the secondary magnet interacts at a preset point with the reed switch armatures.

NOTE: This instrument will provide $\pm 2\%$ accuracy full scale.

INSTALLATION

Check instrument and identify the **HI** and **LO** markings. **HI** identifies the high-pressure port; **LO** the low-pressure port. If the instrument is installed backwards, it will neither operate nor be damaged. The instrument can be line mounted, pipe mounted or panel mounted.

Installation Notes:

- These piston sensor instruments are design for liquid service only...use in gas systems will result in erroneous readings due to excessive piston bypass
- Do not mount directly to steel surfaces...this could affect the magnetic sensors...mounting 1 inch from ferrous metals is recommended
- If there is particulate in the line, insert a screen (approx. 100 micron) to block the particulate from becoming lodged in the instrument
- Do not install on systems for highly viscous fluids or where the fluid may become hardened over time
- Do not install on systems with iron in the fluid...the iron can become attached to the magnetic sensors
- Install the unit above the process lines to prevent particulate from settling in the instrument
- Before installation, refer to our Specification Sheets (on our website) to identify instrument component materials & double check for chemical compatibility

Orange Research

140 Cascade Boulevard, Milford, Connecticut 06460
203 877-5657 800 989-5657 Fax: 203 783-9546
www.orangeresearch.com

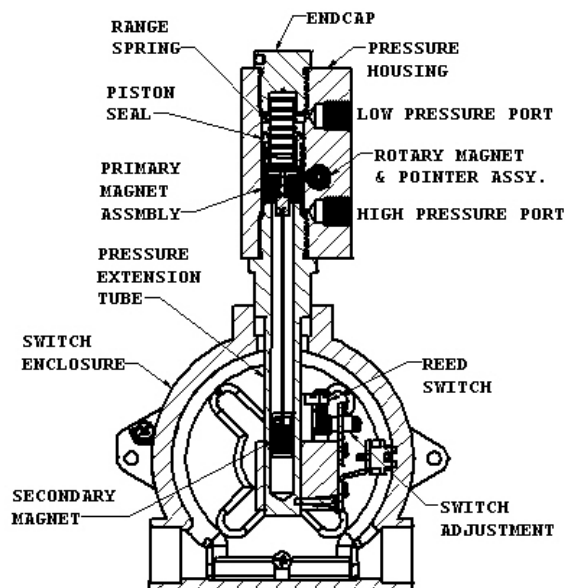

MAINTENANCE

Other than replacing a broken lens, there is only one area where this instrument may need attention. Erratic pointer or switch action may indicate that cleaning is required. For cleaning:

1. Remove the unit from service.
2. Remove end cap with a 1" spanner wrench.
3. Remove the range spring and the piston/magnet assembly. BE CAREFUL NOT TO LOSE STACKING SPACERS, IF ANY.
4. Clean parts in a solvent solution after removing the "O"-ring seals from the end caps since some solvent will attack the seal material.
5. It is good practice to replace the "O"-ring seals while the instrument is dismantled. DO NOT ATTEMPT TO REMOVE THE TEFLON PISTON SEAL FROM THE PISTON. If piston seal is damaged order a new piston/magnet assembly.

To reassemble:

1. Replace the piston assembly. **CAUTION:** Do not bend the stainless-steel wire which connects the secondary magnet to the piston assembly.
2. Make certain that the spacers are seated in the piston spring pocket and reinsert the spring.
3. Reassemble the end cap and tighten. **NOTE:** Be certain that the head of the spring is seated in the end cap spring pocket. The unit is now ready for service.

LENS REPLACEMENT: To remove a threaded retaining ring, unscrew the retaining ring, or to remove the snap ring, pry out the ring with a small screwdriver. Remove the glass chips, insert a new lens and reinstall the snap ring and threaded ring. For snap rings locate the ring joint at the bottom of the gauge.

POINTER REPLACEMENT: (probably damaged when lens was broken). Remove Threaded ring or snap ring as previously described and clean out glass chips. Remove the old pointer with pointer puller or two small screwdrivers opposite each other under pointer hub. Pry off evenly being careful not to bend the pointer shaft. Install new pointer dead on zero. Re-install lens, as described under Lens Replacement.

SWITCH ADJUSTMENT

Reed switch set points are field adjustable. On Indicating Switches, the reed switches can be adjusted over the top 80% of the gauge range. On Switch models the reed switches can be adjusted over the range shown on the instrument label.

Minor Switch Adjustments*

To change the switch adjustment:

1. Unscrew the cover on the electrical enclosure. This cover will be facing the front of the instrument on the lower section of the assembly.
2. Switches can now be adjusted by turning the adjustment screws located above the terminal strips on the switch saddle assembly.
 - A. Clockwise rotation will increase the switch set point.
 - B. Counter-clockwise rotation will decrease the switch set point.
3. Replace the cover.

NOTE: Panel mounting reversed.

* For major switch adjustments, contact Orange Research

SWITCH REPLACEMENT:

1. Unscrew the cover of the electrical enclosure, remove the cover.
2. Disconnect the switch wires from the terminal block. Note the locations of the wires.
3. Remove (2) screws that fasten the terminal block bracket. Remove the bracket (Relay models do not have this bracket).
4. Loosen, BUT DO NOT REMOVE, the (2) switch adjustment plate retaining screws (Relay models will have 3 or 4 retaining screws). Turn screws 3 revolutions counterclockwise. Removal of retaining screws will make re-assembly more difficult.
5. Pull up on the switch adjustment plate and remove the switch & gear assembly (it may be necessary to loosen the saddleblock lock screw and slide the entire saddleblock assembly down towards the conduit connections).
6. Insert the new switch & gear assembly into the saddleblock.
7. Tighten the saddleblock lock screw, if necessary.
8. Tighten the (2) screws on the switch adjustment retaining plate (Relay models will have 3 or 4 retaining screws).
9. Re-assemble the (2) screws that hold down the terminal block bracket.
10. Connect the switch wires to the terminal block.
11. Adjust switch as necessary following the SWITCH ADJUSTMENT procedure.

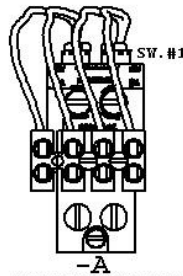

TWO SPST SWITCHES

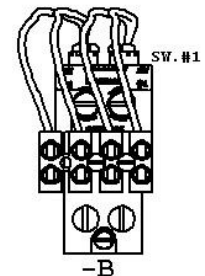
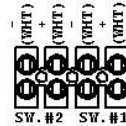

TWO SPST SWITCHES

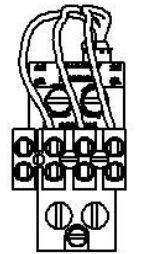
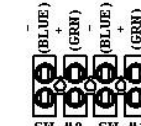

ONE SPDT SWITCH

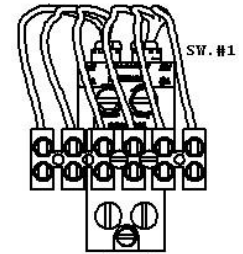
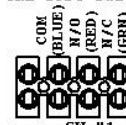

TWO SPDT SWITCHES

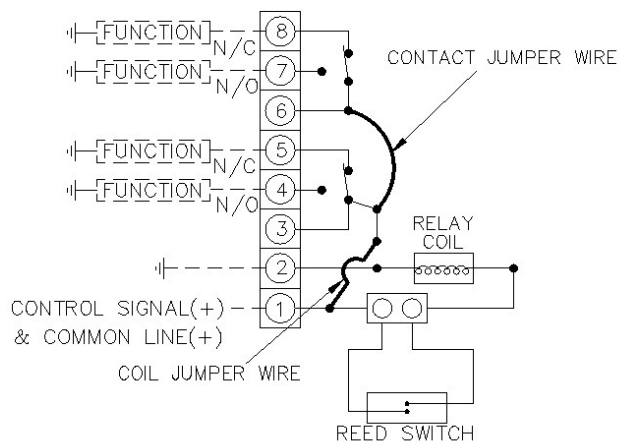

(1) DPDT RELAY
-R1
WET CONTACTS

WARNING: This product contains Nickel, a chemical known to the State of California to cause cancer. For more information go to: www.p65warnings.ca.gov