

DIAL CASE STYLES

**2.5" "B" & 2.5" "F" STYLE
DIAL CASE**

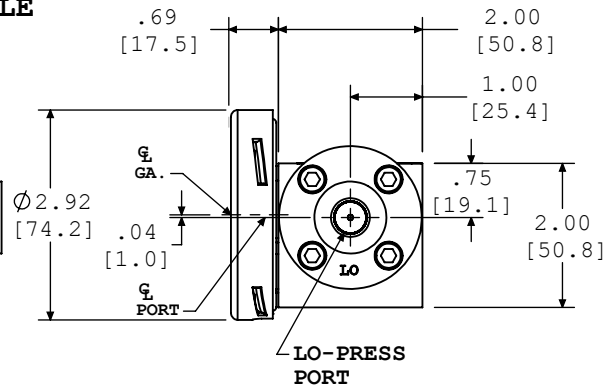

**"B"-STYLE
DIAL CASE**

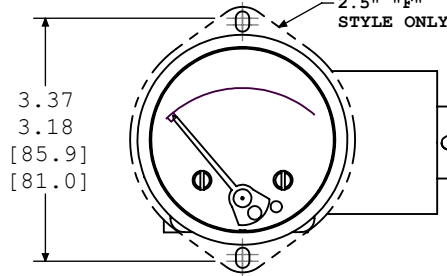
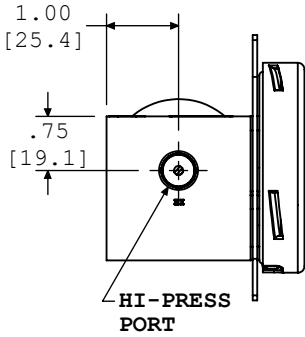
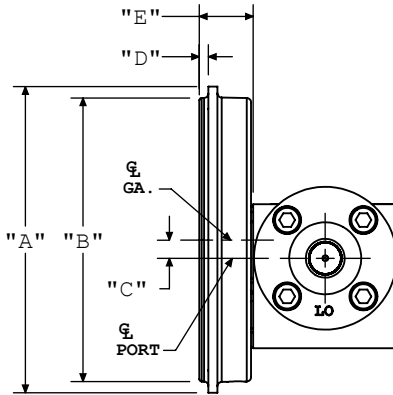
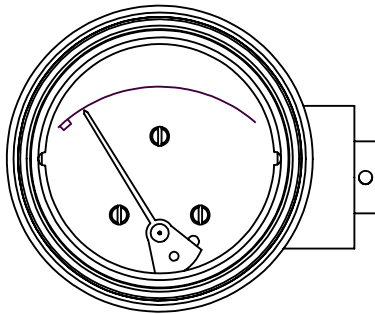

B-STYLE GA. CASE DIMENSIONS			
	3 1/2"	4 1/2"	6.0"
A	4.25 [108]	5.25 [133.4]	6.40 [162.6]
B	3.94 [100.1]	4.94 [125.5]	5.89 [149.6]
C	.38 [9.7]	.75 [19.1]	1.48 [37.6]
D	.13 [3.3]	.13 [3.3]	.39 [9.9]
E	.72 [18.3]	.72 [18.3]	.85 [21.6]

**"F"-STYLE
DIAL CASE**

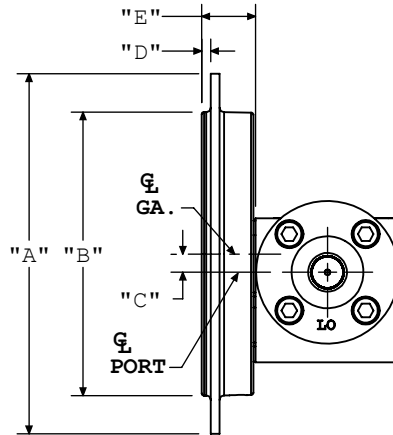
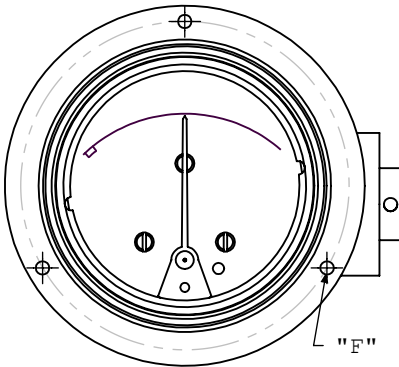

F-STYLE GA. CASE DIMENSIONS			
	3 1/2"	4 1/2"	6.0"
A	5.00 [127]	6.00 [152.4]	7.62 [193.5]
B	3.94 [100.1]	4.94 [125.5]	6.40 [162.6]
C	.38 [9.7]	.75 [19.1]	1.48 [37.6]
D	.13 [3.3]	.13 [3.3]	.39 [9.9]
E	.72 [8.3]	.72 [8.3]	.85 [21.6]
F	PANEL CUTOUT: Ø4.00, 3 MNTG. HOLES Ø.187 EQUALLY SPACED ON A Ø4.56 B.C.	PANEL CUTOUT: Ø5.00, 3 MNTG. HOLES Ø.218 EQUALLY SPACED ON A Ø5.38 B.C.	PANEL CUTOUT: Ø6.50, 3 MNTG. HOLES Ø.218 EQUALLY SPACED ON A Ø7.00 B.C.

PORTING LOCATIONS

